



Origins Series

Custom 1/4" Thick Door Panel Preparation and Installation Instructions for 1175 & 1115 Models

www.U-LineService.com

**Phone (414) 354-0300 • FAX (414) 354-7905
Service & Parts Tech Lines Phone (800) 779-2547 • FAX (414) 354-5696
OnlineService@U-Line.com**

Custom 1/4" Thick Door Panel Insert

Door Panel Preparation

A custom door panel can be inserted into the doorframe. Custom door panels can be flat or raised, as long as the maximum panel thickness where inserted into the door reveal (channel) is 1/4"-thick. For raised panels, the depth of the reveal is 1/4" on all four sides.

IMPORTANT

Raised panels will reduce the door's 90° swing/zero clearance if the unit is installed next to a wall or similar type of structure.

Cut the panel insert to the following dimensions.

Custom 1/4" Dimensions for **1175 Black & White units:**

Width: 22-15/16"
Height: 26-15/16"

Custom 1/4" Dimensions for **1115 Black units:**

Width: 13-15/16"
Height: 26-15/16"

The door panel must not weigh more than 20 lbs.

Door Panel Installation

Install the insert as follows:

⚠ CAUTION

Use care when handling the insert. Insert edges may be sharp.

1. Remove top hinge screw pin with Phillips head screwdriver. Remove door by tilting forward and lifting off bottom hinge pin.

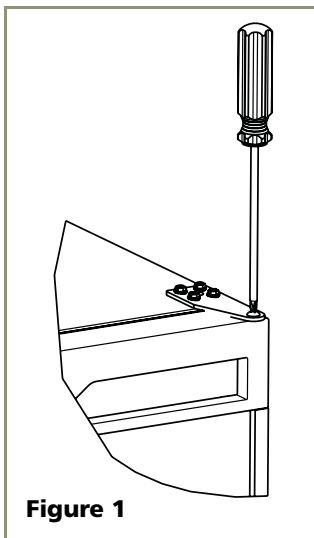

Figure 1

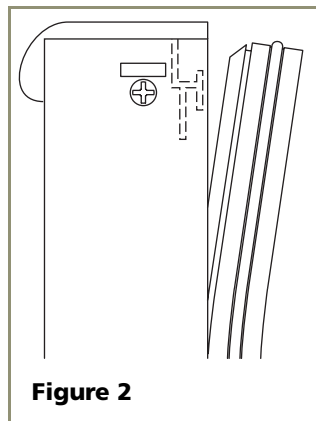

Figure 2

2. Pull door gasket out of groove (top edge of door only). Start in the middle and pull outward, moving toward the edge (see **Figure 2**). This may take some force.
3. Remove two outside screws holding door handle. Slightly separate door handle from door (see **Figure 3**).
4. Pull handle up and off.

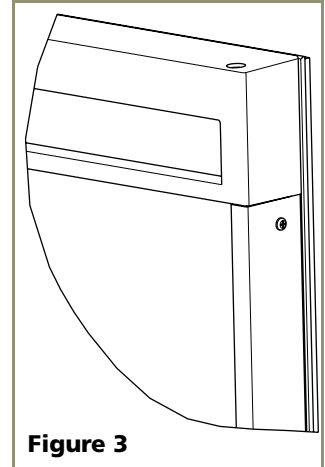

Figure 3

IMPORTANT

Use care not to damage magnet, located on door bottom when installing door insert. Do not set door on bottom edge when pushing insert into place.

5. Slide custom door panel insert into 1/4-inch channel in door front.
6. Holding door gasket out of the way, replace handle on door, making sure it is seated properly on insert and that screw holes line up.
7. Install two small screws removed in **Step 3**.
8. Starting at the corners and working inward, push door gasket into place on door.
9. Place door on bottom hinge pin and install upper hinge screw.

Origins Series

Checking Door Alignment

The unit's door is aligned at the factory before shipment. However, its alignment could have been disturbed during shipment or during door panel installation.

IMPORTANT

Properly aligned, the door's gasket should be firmly in contact with the cabinet all the way around the door (no gaps).

1. Carefully examine the door's gasket to assure that it is firmly in contact with the cabinet.

Note: When inspecting door alignment, make sure the magnet is aligned with the switch behind the grille. Also make sure the door gasket is not pinched on the hinge side of the door.

2. If the door is not properly aligned, use the following procedure.

Adjusting Door Alignment

1. Loosen (do not remove) top and bottom hinge screws. See **Figure 4**.
2. Align door squarely with cabinet. Make sure gasket is firmly in contact with cabinet all the way around the door (no gaps).
3. Tighten bottom hinge screws.
4. Tighten top hinge screws.

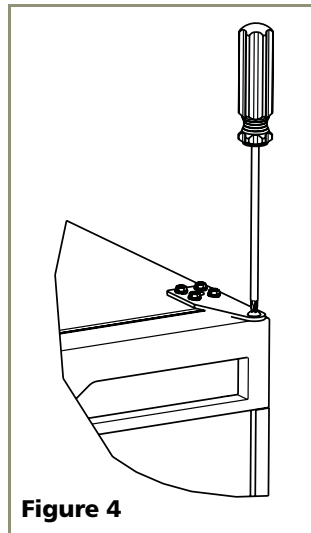

Who to Call

Service Information

If the need for service arises, contact the dealer from whom the unit was purchased. State the Model Number and Serial Number and explain the problem. The Model and Serial Number plate is located inside unit at upper right hand corner.

If you need to locate a service company, you can go online at **www.U-LineService.com** and search for a service company by zip code.

For more than four decades, U-Line has distinguished itself as the leader in built-in undercounter ice making, refrigeration and wine storage appliances.

Echelon™ SERIES / *Origins* SERIES

U-Line Corporation, located in Milwaukee, WI, is a family operated manufacturer of built-in undercounter icemakers, Combo® icemaker/refrigerators, Wine Captain® wine storage units, refrigerators, refrigerated drawers and refrigerator/freezers.