

Model: XCK-1S-2



## KEGCO 24" WIDE DUAL TAP STAINLESS STEEL COMMERCIAL KEGERATOR

### FEATURES

- COMMERCIAL GRADE
- HEAVY-DUTY STAINLESS STEEL TOP
- BUILT-IN DRIP TRAY WITH DRAIN
- STAINLESS STEEL INTERIOR WALLS AND CEILING
- DIGITAL TEMPERATURE CONTROL
- AIR COOLED TOWER PREVENTS FOAM

### CAPACITY OPTIONS

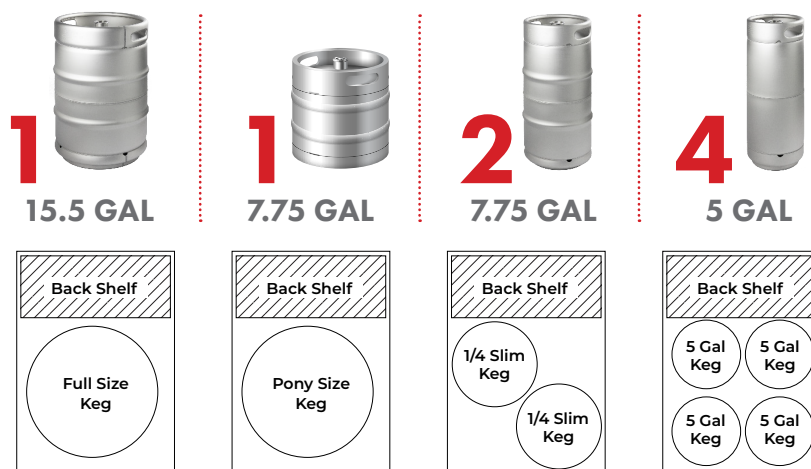

### DESCRIPTION

- Ideal for busy restaurants, pubs, bars and tasting rooms
- Durable steel construction with stainless steel top and built-in drip tray to collect spills
- Easily holds a full size keg or multiple smaller kegs
- Customize the draft beer dispense system to suit your particular needs
- NSF compliant and ETL sanitation listed for commercial use



 (800) 710 9939

support@beveragefactory.com  
www.beveragefactory.com

#### OUR SHOWROOM

8510 Miralani Drive  
San Diego, CA 92126

Mon-Fri, 7:00am - 4:00pm



Model: **XCK-1S-2**

## KEGCO 24" WIDE DUAL TAP ALL STAINLESS STEEL COMMERCIAL KEGERATOR

DIMENSIONS	
Height (without casters)	34"
Height (with casters)	39"
Width	23.5"
Depth	30.25"
Shipping Dimensions	28"x36"x46"

WEIGHT	
Unit Weight	143 lbs.
Shipping Weight	187 lbs.

KEG STORAGE CAPACITIES	
Full Size / 1/2-Barrel	1
Pony Size / 1/4-Barrel	1
1/4-Barrel Slim	2
1/6-Barrel	3 (4 with external nitrogen tank)
5 gal. Ball/Pin Lock Keg	3 (4 with external nitrogen tank)

CONTROLS	
Adjustable Thermostat	Yes
Digital	Yes

KEY FEATURES	
Built-in Capable	No
Keg Coupler	Optional Add-On
Security Lock	Yes
Regulator	Optional Add-On
CO <sub>2</sub> Tank	Optional Add-On
Cleaning Kit	Optional Add-On
Outdoor Use	No
Commercial Use	Yes

ELECTRICAL	
Electrical Requirements	115v/60hz
Running Amps	1.8 A

CERTIFICATIONS	
ETL Listed	Yes
ETL Sanitation Listed	Yes

WARRANTY	
Labor	1 Year
Parts	1 Year
Compressor (Parts Only)	5 Years

EXTERIOR	
Cabinet	Stainless Steel
Drip Tray	Yes
Guard Rail	Yes
Casters	Yes

DOOR	
Color / Material	Stainless Steel
Number of Doors	1
Door Handle	Recessed
Field Reversible	No
Accepts Custom Overlay Panel	No

DRAFT BEER TOWER	
Number of Faucets	2
Material	Stainless Steel
Height	14.25"
Diameter	3"

COOLING SYSTEM	
Type	Compressor
Defrost System	Automatic
Front Ventilation	No

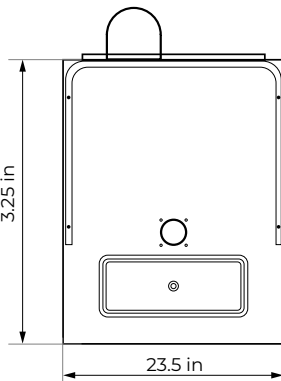
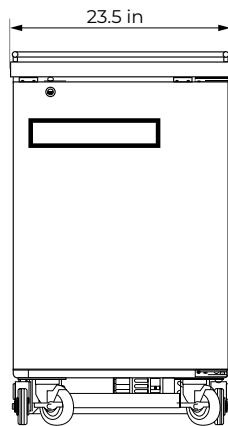
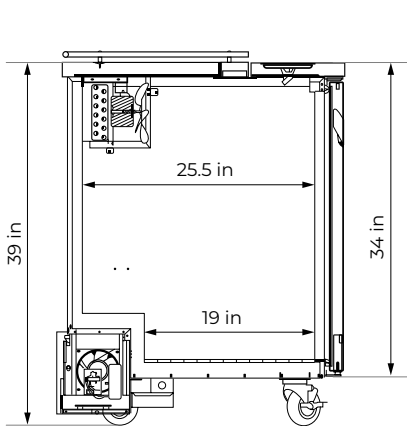

**(800) 710 9939**

support@beveragefactory.com  
www.beveragefactory.com

### OUR SHOWROOM

8510 Miralani Drive  
San Diego, CA 92126

Mon-Fri, 7:00am - 4:00pm